

Features

- 85~264Vac input range
- Global certificates in multi-fields (ITE 62368-1, Industrial 61558-1/-2-16, 61010)
- 30mm slim width
- High efficiency up to 91% and no load power dissipation 0.6W~1W
- Built-in constant current limiting circuit
- Protections: Short circuit / Overload / Over voltage / Over temperature
- Fanless design, cooling by free air convection
- Over voltage category III (OVC III)
- -40~+70°C wide range operation temperature (>+50°C derating)
- Operating altitude up to 5000 meters
- Built-in DC OK relay contact
- Can be installed on DIN rail TS-35/7.5 or 15
- 3 years warranty

Applications

- Industrial control system
- Semiconductor fabrication equipment
- Factory automation
- Electro-mechanical apparatus
- Battery charger

GTIN CODE

MW Search: <https://www.meanwell.com/serviceGTIN.aspx>

Description

The XDR-120E series is a 120W AC/DC economical ultra slim industrial DIN rail power. Key features of this series include a narrow 30mm casing, optimizing system installation space, and an ultra-wide input range of 85~264Vac suitable for global use. It boasts a maximum efficiency of 91% and a low standby power consumption 0.6W~1W for energy savings and carbon reduction. It has built-in constant current, fanless design, a wide operating temperature range of -40 to +70°C (up to +50°C at full load); OVCIII compliance; built-in DC OK signal. With comprehensive protection functions, complete safety certifications, and a 3-years warranty, the XDR-120E series is a compact, high-performance, and highly reliable DIN rail power supply.

Model Encoding

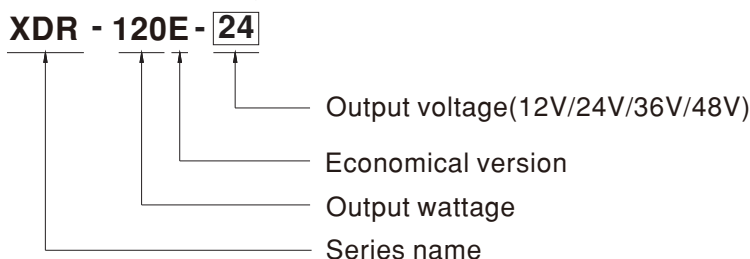



120W AC/DC Economical Ultra Slim Industrial DIN Rail Power **XDR-120E** series

SPECIFICATION	XDR-120E-12	XDR-120E-24	XDR-120E-36	XDR-120E-48
OUTPUT				
DC VOLTAGE	12V	24V	36V	48V
RATED CURRENT	10A	5A	3.33A	2.5A
CURRENT RANGE	0 ~ 10A	0 ~ 5A	0 ~ 3.33A	0 ~ 2.5A
RATED POWER	120W	120W	119.88W	120W
RIPPLE & NOISE (max.) Note.2	100mVp-p	120mVp-p	150mVp-p	150mVp-p
VOLTAGE ADJ. RANGE	12 ~ 15V	24 ~ 29V	36 ~ 42V	48 ~ 55V
VOLTAGE TOLERANCE Note.3	± 2.0%	± 1.0%	± 1.0%	± 1.0%
LINE REGULATION	± 0.5%	± 0.5%	± 0.5%	± 0.5%
LOAD REGULATION	± 1.0%	± 1.0%	± 1.0%	± 1.0%
SETUP, RISE TIME	1200ms, 60ms/230Vac 2500ms, 60ms/115Vac at full load			
HOLD UP TIME (Typ.)	16ms/230Vac 8ms/115Vac at full load			
INPUT				
AC VOLTAGE RANGE	85 ~ 264Vac			
DC VOLTAGE RANGE	120 ~ 370Vdc			
NO LOAD POWER CONSUMPTION (Typ.)	0.6W @115Vac 0.9W @ 230Vac	0.8W @115Vac 1W @ 230Vac		
FREQUENCY RANGE	47 ~ 63Hz			
EFFICIENCY (Typ.)	89%	91%	91%	91%
AC CURRENT (Typ.)	2.3A/115Vac 1.3A/230Vac			
INRUSH CURRENT (Typ.)	COLD START 20A/115Vac 40A/230Vac			
LEAKAGE CURRENT	<1mA / 240Vac			
PROTECTION				
OVERLOAD	105-130% rated output power, constant current limiting without shutdown , recovers automatically after fault condition is removed			
OVER VOLTAGE	15 ~ 18V	30 ~ 34V	43 ~ 50V	56 ~ 65V
	Protection type : Shut down o/p voltage, re-power on to recover			
OVER TEMPERATURE	Protection type : Shut down o/p voltage,recovers automatically after fault condition is removed			
FUNCTION				
DC OK RELAY CONTACT	Relay Contact Ratings (max.):30Vdc/1A, 30Vac/0.5A resistive load			
ENVIRONMENT				
WORKING TEMP. Note.4	-40 ~ +70°C (Refer to "Derating Curve")			
WORKING HUMIDITY	20 ~ 95% RH non-condensing			
STORAGE TEMP., HUMIDITY	-40 ~ +85°C, 10 ~ 95% RH non-condensing			
TEMP. COEFFICIENT	± 0.03% /°C (0 ~ 50°C)			
VIBRATION	Component:10 ~ 500Hz, 2G 10min./1cycle, 60min. each along X, Y, Z axes; Mounting: Compliance to IEC60068-2-6			
SAFETY & EMC Note.7				
SAFETY STANDARDS	UL/CUL 61010-1/-2-201; TUV BS EN/EN 62368-1, BS EN IEC/EN IEC 61558-1/-2-16, BS EN/EN 61010-1/-2-201; CB IEC 62368-1, IEC 61558-1/-2-16, IEC 61010-1/-2-201; RCM AS/NZS 62368-1, AS/NZS 61558-1/-2-16; BSMI CNS15598-1; CCC GB4943.1; EAC TPTC004 approved; KC KC62368-1 and BIS IS13252 (Part 1):2010 certified, no stock ,contact sale for inquires			



120W AC/DC Economical Ultra Slim Industrial DIN Rail Power **XDR-120E** series

SPECIFICATION	XDR-120E-12	XDR-120E-24	XDR-120E-36	XDR-120E-48
SAFETY & EMC Note.7				
OVER VOLTAGE CATEGORY Note.5	IEC/EN 61558-1/-2-16 (OVC III, altitude up to 2000m) IEC/EN/UL 61010 (OVC II, altitude up to 5000m) IEC/EN 62368-1 (OVC II, altitude up to 5000m)			
SAFETY EXTRA-LOW VOLTAGE(SELV)	IEC/EN 61558-2-16 (SELV) IEC/EN/UL 61010-2-201 (SELV) IEC/EN 62368-1 (SELV / ES1)			
WITHSTAND VOLTAGE	I/P-O/P: 4KVac I/P-FG: 2KVac O/P-FG: 1.5KVac O/P-DC OK: 0.5KVac			
ISOLATION RESISTANCE	I/P-O/P, I/P-FG, O/P-FG: 100M Ohms/500Vdc/25 °C / 70%RH			
EMC EMISSION	Parameter	Standard		Test Level / Note
	Conducted	BS EN/EN55032 (CISPR32) / BS EN/EN61204-3 / CNS15936		Class B
	Radiated	BS EN/EN55032 (CISPR32) / BS EN/EN61204-3 / CNS15936		Class B
	Harmonic Current	BS EN/EN61000-3-2		Class A
	Voltage Flicker	BS EN/EN61000-3-3		-----
EMC IMMUNITY	BS EN/EN55035 , BS EN/EN61204-3, BS EN/EN61000-6-2(BS EN/EN50082-2)			
	Parameter	Standard		Test Level / Note
	ESD	BS EN/EN61000-4-2		Level 3, 8KV air ; Level 2, 4KV contact; criteria A
	Radiated	BS EN/EN61000-4-3		Level 3, 10V/m ; criteria A
	EFT / Burst	BS EN/EN61000-4-4		Level 3, 2KV ; criteria A
	Surge	BS EN/EN61000-4-5		Level 4, 2KV/Line-Line ;Level 4, 4KV/Line-Line-Chassis ;criteria A
	Conducted	BS EN/EN61000-4-6		Level 3, 10V ; criteria A
Magnetic Field	BS EN/EN61000-4-8		Level 4, 30A/m ; criteria A	
OTHERS				
MTBF	2223.1K hrs min. Telcordia SR-332 (Bellcore) ; 440.4K hrs min. MIL-HDBK-217F (25°C)			
DIMENSION	30*125.2*116mm (W*H*D)			
PACKING	510g; 24pcs/13.25Kg/1.16CUFT			
NOTE				
<p>1. All parameters NOT specially mentioned are measured at 230Vac input, rated load and 25°C of ambient temperature.</p> <p>2. Ripple & noise are measured at 20MHz of bandwidth by using a 12" twisted pair-wire terminated with a 0.1 μF & 47 μF parallel capacitor.</p> <p>3. Tolerance : includes set up tolerance, line regulation and load regulation.</p> <p>4. When the temperature is between -40 °C and -20 °C and the input voltage is between 85V and 90V, the temperature derating curve drops to 40% .</p> <p>5. The ambient temperature derating of 3.5°C/1000m with fanless models and of 5°C/1000m with fan models for operating altitude higher than 2000m(6500ft).</p> <p>6. Installation clearances : 40mm on top, 20mm on the bottom, 5mm on the left and right side are recommended when loaded permanently with full power. In case the adjacent device is a heat source, 15mm clearance is recommended.</p> <p>7. The power supply is considered a component which will be installed into a final equipment. The final equipment must be re-confirmed that it still meets EMC directives. (as available on https://www.meanwell.com/Upload/PDF/EMI_statement_en.pdf)</p> <p>※ Product Liability Disclaimer : For detailed information, please refer to https://www.meanwell.com/serviceDisclaimer.aspx</p>				

■ Block Diagram

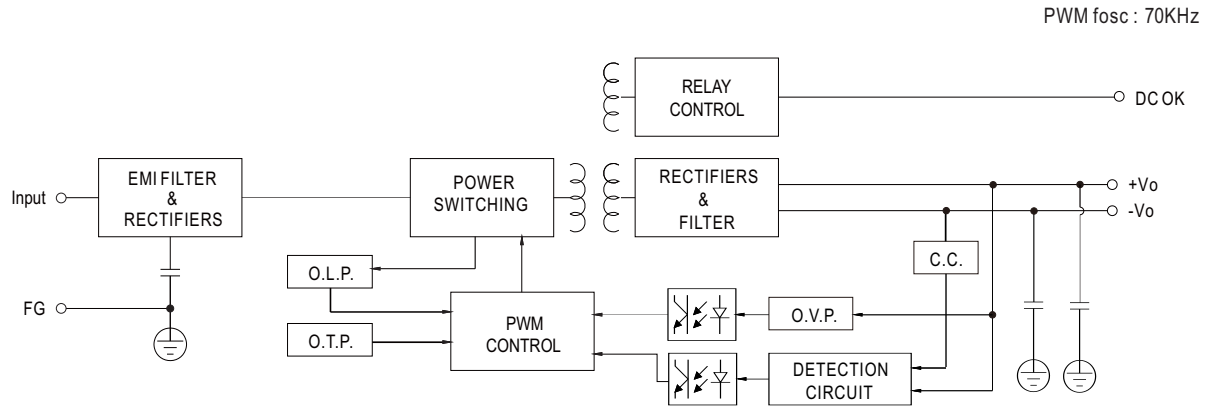

■ Derating Curve

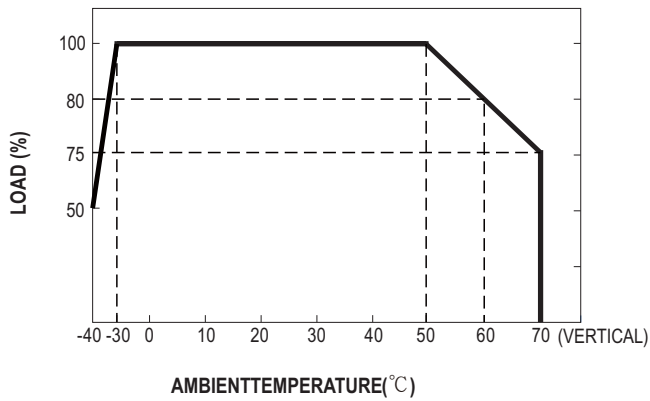

■ Static Characteristics

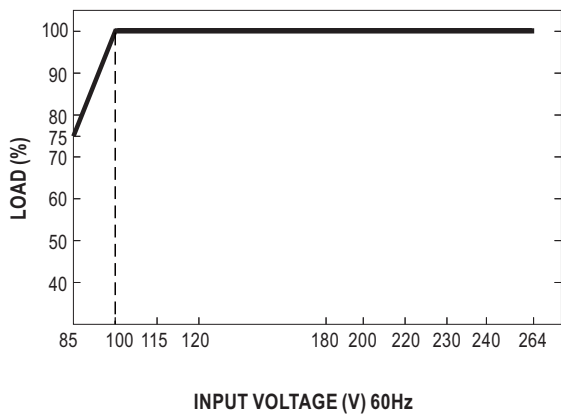

■ **Function Manual**

1. DC OK Relay Contact

Contact Close	PSU turns ON / DC OK.
Contact Open	PSU turns OFF / DC Fail.
Contact Ratings (max.)	30Vdc/1A, 30Vac/0.5A resistive load.

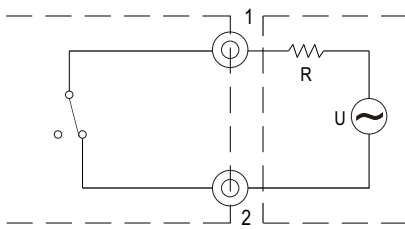

External voltage source (U) and resistor (R)
(The max. Sink is 30Vdc/1A, 30Vac/0.5A)

Internal circuit of DC_OK, via relay contact

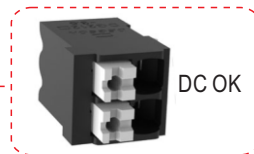
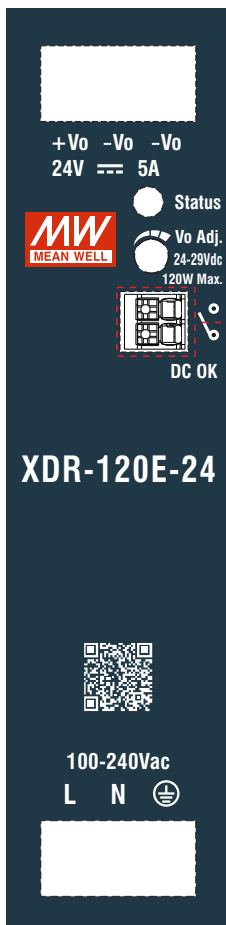

■ Mechanical Specification

(Unit:mm , Tolerance ± 1 mm)

Case No.301

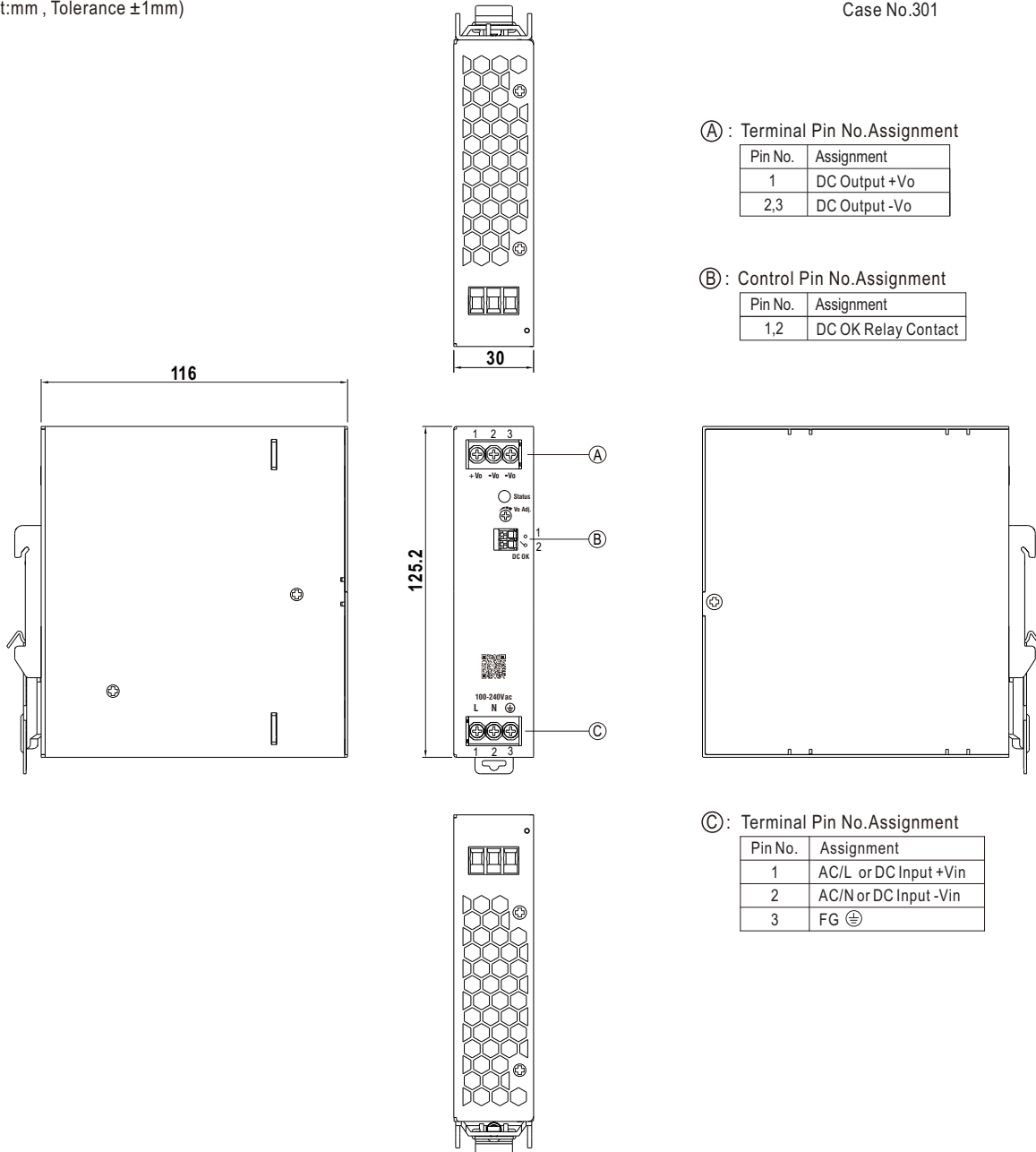

■ Recommend Wiring

	AC Input T.B	DC Output T.B	Signal connector
Solid Wire	6mm ² max.	6mm ² max.	1.5mm ² max.
A.W.G	16~10 AWG	16~10 AWG	24~16 AWG
Wire Stripping Length	7~8mm	7~8mm	8~9mm
Screw Terminal Torque	5 Lb-In	5 Lb-In	/



■ Installation Instruction

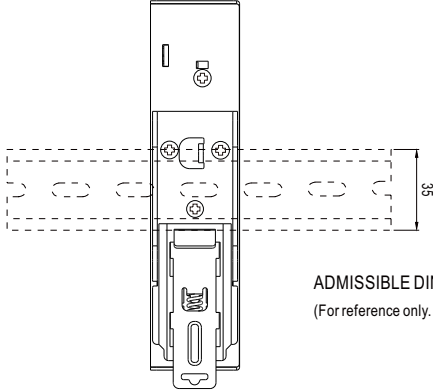

ADMISSIBLE DIN-RAIL: TS35/7.5 OR TS35/15
(For reference only. Not included with unit.)

This series fits DIN rail TS35/7.5 or TS35/15.
For installation details, please refer to the Instruction manual.

■ Installation Manual

Please refer to : <http://www.meanwell.com/manual.html>